

Dimensions

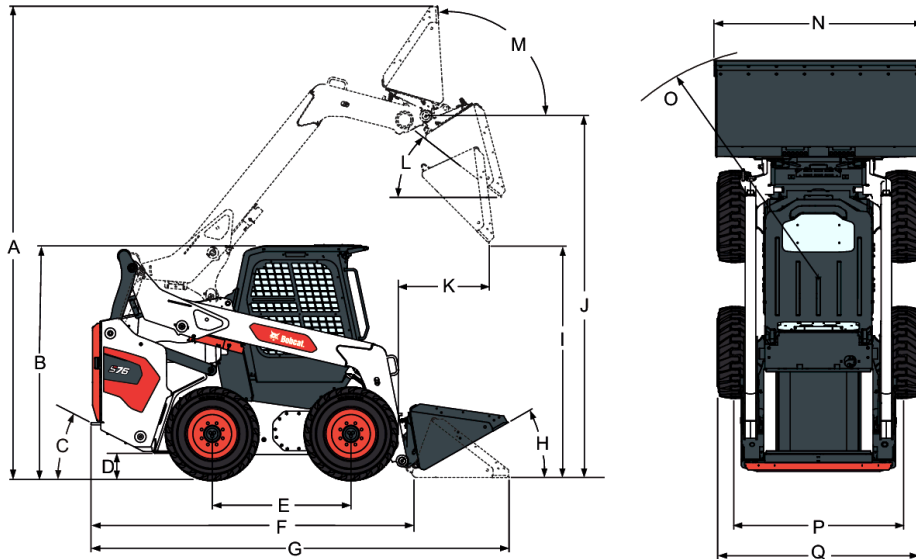

(A) Operating height	4251.8 mm
(B) Height with operator cab	2078.7 mm
(C) Angle of departure	27.0°
(D) Ground clearance	234.5 mm
(E) Wheelbase	1227.0 mm
(F) Length without attachment	2892.8 mm
(G) Length with standard bucket	3736.6 mm
(H) Rollback at ground position	30.0°
(I) Dump height with standard bucket	2526.1 mm
(J) Height to bucket hinge pin	3258.5 mm
(K) Dump reach at maximum height	950.1 mm
(L) Dump angle at maximum height	37.0°
(M) Rollback fully raised at maximum height	94.0°
(N) Width over standard bucket	1879.6 mm
(O) Turning radius with standard bucket	2227.5 mm
(P) Track, standard tyres	1584.4 mm
(Q) Width over standard tyres	1828.8 mm

Performance

Tipping load (ISO 14397-1)	2722 kg
Rated operating capacity (ISO 14397-1)	1367 kg
Lift breakout force	2608 daN
Tilt breakout force	2654 daN

Cycle Times

Raise lift arms	3.9 s
Lower lift arms	2.6 s
Bucket rollback	1.7 s
Bucket dump	2.3 s

Weights

Operating weight	4038 kg
Shipping weight	3597 kg

Engine

Make / Model	Bobcat 2.4L, 97/68 EC Stage V
Fuel	Diesel
Cooling	Liquid
Power at 2600 RPM	54.5 kW
Torque at 1800 RPM (SAE J1995 Gross):	283.9 Nm
Number of cylinders	4
Displacement	2400 cm ³
Bore	90.0 mm
Stroke	94.0 mm
Lubrication	Gear pump pressure
Crankcase ventilation	Closed breathing
Air filter	Dry replaceable cartridge with safety element
Ignition	Diesel-compression
Starting aid	Glow Plugs

Electrical

Alternator	Belt driven — 90 A — open
Battery	12 V — 950 A cold cranking at -18°C — 180 min reserve capacity
Starter	12 V — gear reduction type — 3.0 kW

Hydraulic System

Pump type	Engine driven, gear type
Pump capacity	88.10 L/min
Pump capacity (with high flow option)	114.70 L/min
System relief at quick couplers	23.8-24.5 MPa
Control valve	Three-spool, open-centre type with float detent on lift and electrically controlled auxiliary spool
Hydraulic filter	Full-flow replaceable — 10 µm synthetic media element
Fluid lines	SAE standard tubelines, hoses, and fittings

Hydraulic Cylinders

Lift cylinder (2)	Double-acting
Lift cylinder bore	76.2 mm
Lift cylinder rod	44.5 mm
Lift cylinder stroke	633.2 mm
Tilt cylinder (2)	Double-acting with cushioning feature on dump and rollback
Tilt cylinder bore	76.2 mm
Tilt cylinder rod	41.4 mm
Tilt cylinder stroke	355.0 mm

Drive System

Transmission	Infinitely variable tandem hydrostatic piston pumps, driving two fully reversing hydrostatic motors
Final drive chains	Pre-stressed #120 HSOC endless roller chain (no master link) and sprockets in sealed chaincase with oil lubrication. (Chains do not require periodic adjustments.) Two chains per side with no idler sprocket.
Main drive	Fully hydrostatic; four-wheel drive
Axle size	70.1 mm, heat treated. Axle tubes welded to chaincase. Labyrinth axle seal protection.
Wheel bolts	Eight 9/16-inch wheel bolts fixed to axle hubs

Traction

Standard tyres	12 x 16.5, 12-ply, Bobcat heavy duty
Heavy duty tyres	12 x 16.5, 12-ply, Bobcat heavy duty, offset rims
Severe duty tyres	12 x 16.5, 12-ply, Bobcat severe duty
Poly fill tyres (option)	12 x 16.5, 12-ply, Bobcat severe duty, poly filled
Solid flex tyres (option)	12 x 16.5, Bobcat solid flex
Float tyres	33 x 15.5-16.5, 12-ply, Bobcat superflotation, offset rims
Max. travel speed (low range)	10.9 km/h
Max. travel speed (high range - option)	19.0 km/h

Fluid Capacities

Chaincase reservoir	39.20 L
Cooling system	11.40 L
Engine oil with filter	11.40 L
Fuel tank	120.00 L
Hydraulic reservoir	10.20 L
Hydraulic / Hydrostatic system	45.00 L

Fluid Specifications

Engine coolant

Propylene glycol/water mix (53% - 47%) with freeze protection to -37°C
 5 L can - 6904844A, 25 L container - 6904844B, 209 L drum - 6904844C, 1000 L tank - 6904844D
 Propylene glycol concentrate coolant 5 L can - 6987646A, 25 L container - 6987646B, 209 L drum - 6987646C, 1000 L tank - 6987646D

Engine oil

Oil must meet API Service Classification of CL4 or better. Recommended SAE viscosity number for anticipated temperature range.

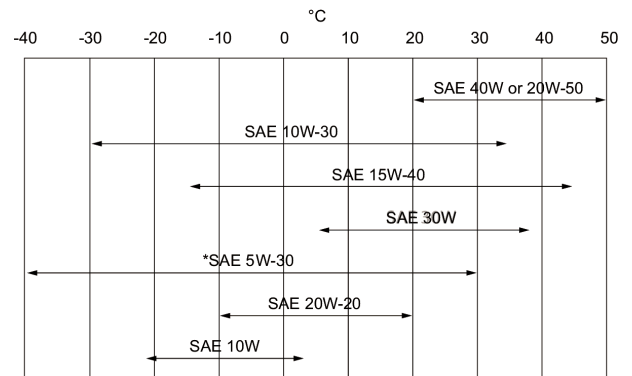

* Can be used only when available with appropriate diesel rating. For synthetic oil use the recommendation from the oil manufacturer.

Hydraulic fluid

Bobcat Superior SH, 5 L can - 6904842A, 25 L container - 6904842B, 209 L drum - 6904842C, 1000 L tank - 6904842D
 Bobcat Bio Hydraulic, 5 L can - 6904843A, 25 L container - 6904843B, 209 L drum - 6904843C, 1000 L tank - 6904843D

Motor oil is not an acceptable alternative fluid.

Controls

Engine Starting

Hand lever throttle

Key-type starter switch and shutdown or optional keyless start. Glow plugs automatically activated by standard or Deluxe instrument panel.

Front auxiliary (standard)

Electrical switch on right-hand steering lever

Rear auxiliary (optional)

Electrical switch on left-hand steering lever

Loader hydraulics tilt and lift

Selectable Joystick Controls (SJC) or separate foot pedals

Service brake

Two independent hydrostatic systems controlled by two hand-operated steering levers

Secondary brake

One of the hydrostatic transmissions

Parking brake

Mechanical disc, hand-operated rocker switch on dash panel

Parking brake, two-speed option

Spring-applied pressure release multi-disk brake activated by rocker switch

Vehicle steering

Direction and speed controlled by Selectable Joystick Controls (SJC) or two hand levers

Auxiliary pressure release

Pressure is relieved through the coupler block. Push in and hold for 5 s.

Instrumentation

The following loader functions are monitored by a combination of gauges and warning lights in the operator's line of sight. The system alerts the operator of monitored loader malfunctions by way of audible alarm and visual warning lights.

Standard Instrument Panel

- Gauges
 - Engine coolant temperature
 - Fuel
- Indicators
 - Bobcat Interlock Control System
 - Engine preheat
 - Two speed
 - Turn signals
- Warning lights
 - Engine temperature
 - Fuel level
 - General warning
 - Seat belt
 - Seatbar down
 - Engine malfunction
 - Hydraulic system malfunction
 - Lift and tilt valve, hydraulics lock-out
 - Parking brake
 - Hydraulic oil temperature
 - Engine oil pressure
 - Hydraulic oil pressure
- Buttons
 - Work lights and road lights
 - High flow auxiliary hydraulics
 - Auxiliary hydraulics
 - Information (Hour meter, Engine RPM, Battery voltage, Service codes, Service reminder, Maintenance clock)
 - Traction lock override
 - Press to operate loader
- Rocker switch
 - Parking brake
- Alarm
 - Beep when error, warning or shutdown condition exists

Deluxe Instrument Panel

Same gauges, warning lights and other features as Standard Instrument Panel, plus:

- Gauges
 - Engine oil pressure / temperature
 - Hydrostatic charge pressure
 - Hydraulic oil temperature
 - Battery

- Additional features
 - Keyless start with password capability
 - Digital clock, date and time
 - User name and hourmeter
 - Attachment control information
 - Current job hours
 - High Flow lockouts
 - Multi-language display
 - Help screens
 - Diagnostic capability
 - Engine/hydraulic systems shutdown function
 - Password lockout
- Icons
 - Active warnings
 - Vitals (Engine speed, Oil Pressure, Temperature, System voltage, Hydraulic charge pressure, Oil temperature)
 - Service
 - Main screen
 - Attachments
 - Security
 - Display
- Buttons
 - Left scroll
 - Enter
 - Right scroll

Serviceability

Access is available to the following through the rear door/tailgate and rear screen:

- Air cleaner
- Alternator
- Battery
- Cooling system (engine oil and hydraulic oil coolers easily separable for cleaning)
- Engine oil and fuel filters
- Engine oil drain and dipstick
- Hydraulic oil fill and filter (access at the upper right side of the machine)
- Starter

Axle hubs provide protection for the axle seals

Bob-Tach™ pivots have replaceable wear bushings

Easy access to all grease points

Rod end of the tilt cylinder has a replaceable bushing

Tailgate has an optional lock for vandal-proofing

Tailgate is equipped with door-stop to hold door open while servicing

Tip-up operator cab gives access to certain hydraulic system components

Standard Features

- 12 x 16.5, 10-ply, Heavy duty tyres
- 3 Point Seat belt
- 5" Deluxe Instrumentation (Radio Ready)
- High-back adjustable suspension seat
- Backup Alarm
- Bob-Tach™ Attachment System
- Deluxe pressurized cab with HVAC
- Dual Direction Bucket Positioning (including ON/OFF switch)

- High flow hydraulics
- Horn
- Key start
- LED Working Lights front and rear
- Selectable Joystick Controls (SJC)
- Spark arrestor muffler
- Two Speed Travel
- Auxiliary hydraulics: variable flow/maximum flow
- Bobcat Interlock Control System (BICS)
- Engine/hydraulics system shutdown
- Machine IQ (telematic)
- Lift arm support
- Manual
- Parking brake
- Seat belt
- Warranty: 24 months or 2000 hours (whichever occurs first)

Options

- Factory Options
 - 12 x 16.5, 10-ply, Heavy duty tyres, offset rims
 - 12 x 16.5, 10-ply, Severe duty tyres
 - 12 x 16.5, Solid flex tyres
 - 33 x 12-16.5, 10-ply, Superflotation tyres , offset rims
 - 7" Touch Display (Integrated Bluetooth, Hands Free Calling, Radio, Reversing Camera)
 - Auto HVAC
 - Auto Ride Control
 - Beacon
 - Clear View Cab
 - Heated Cloth Air ride seat with 3 point seat belt
 - Manual Hand and Foot Controls
 - Radio
 - Reversible Fan
 - Power Bob-Tach™
 - Reversing Camera
 - Strobe

- Dealer Installed Options
 - Engine block heater kit
 - Pre-cleaner HP aspiration kit
 - Deluxe instrument panel
 - Catalytic purifier kit
 - Radio kit
 - Back up alarm kit
 - Bucket positioning kit
 - Fire extinguisher kit
 - Rotating beacon kit
 - Road kit
 - Single-point lift kit
 - Fresh air heater kit
 - Front door kit
 - Plumbing kit for fresh air heater
 - Keyless kit
 - Power Bob-Tach™ kit
 - Air conditioning kit
 - 200/300 lbs (74.4/111.9 kg) counterweight kit
 - Lexan rear window kit
 - Special applications front door kit
 - Four-point lift kit
 - 7- and 14-pin electrical attachment control kit (7-pin kit standard with S650H)
 - FOPS kit **
 - Rear auxiliary hydraulic kit

Attachments

- Auger Accessories
- Augers
- Box Blades
- Breaker Accessories
- Breakers
- Brushcat™ Rotary Cutters
- Brush Saws
- Combination Buckets
- Concrete Mixers
- Concrete Pumps
- Construction / Industrial Buckets
- Diggers
- Dozer Blades
- Drop Hammers
- Dumping Hoppers
- Flail Cutters
- Forestry Cutters
- Graders
- Grapples, Industrial
- Landplanes
- Landscape Rakes
- Laser Equipment
- Low Profile Buckets
- Miscellaneous
- Mixing Buckets
- Rear Stabilizers
- Remote Control
- Root Grapples
- Rotary Grinders
- Sand Cleaners
- Scarifiers
- Scrapers
- Seeders
- Skeleton Buckets
- Snow Blades
- Snow Pushers
- Snow V-Blades
- Sod Layers
- Soil Conditioners
- Spreader
- Spreaders
- Stump Grinders
- Sweepers
- Tillers
- Tilt-Tatch
- Tree Transplanters
- Trench Compactors
- Trenchers
- Utility Forks
- Utility Frames

- Pallet Fork Accessories
- Pallet Forks, Hydraulic
- Planer Accessories
- Planers
- Vibratory Rollers
- Wheel Saws
- Wood Chippers

Environmental

Operator LpA(98/37 & 474-1)	77 dB(A)
Noise level LWA(EU Directive 2000/14/EC)	101 dB(A)
Whole body vibration (ISO 2631-1)	0.59 ms ⁻²
Whole body vibration uncertainty	0.30 ms ⁻²
Hand-arm vibration (ISO 5349-1)	1.16 ms ⁻²