

Dimensions

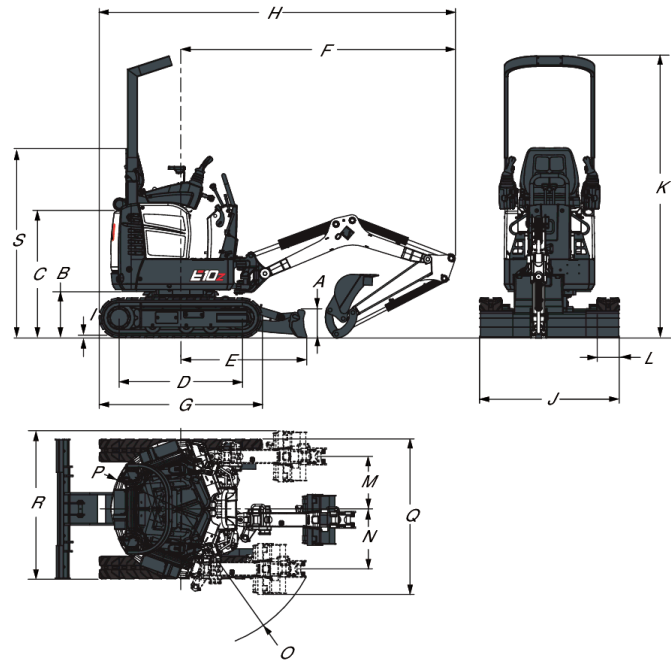

(A) Blade height	220.0 mm
(B) Clearance, upper structure to ground line	363.0 mm
(C) Ground line to top of engine cover	992.0 mm
(D) Length of track on ground	968.0 mm
(E) Machine centre line to blade	987.0 mm
(F) Minimum radius in travel position	2153.0 mm
(G) Overall length of track assembly	1280.0 mm
(H) Overall length in travel position	2793.0 mm
(I) Track lug height	16.0 mm
(J) Blade width	710.0 mm
(J) Blade width (extensions extended)	1100.0 mm
(K) Height	2209.0 mm
(S) Height (Folded)	1490.0 mm
(L) Track width	180.0 mm
(M) Machine centre line to working equipment centre line, left-hand rotation	413.0 mm
(N) Machine centre line to working equipment centre line, right-hand rotation	471.0 mm
(O) Minimum turning radius	1121.0 mm
(P) Swing clearance, rear	550.0 mm
(Q) Working width at maximum right-hand rotation, long dipperstick	1221.0 mm
(R) Working width at maximum left-hand rotation, long dipperstick	1162.0 mm
(•) Boom length (boom pivot to arm pivot)	1276.0 mm
(•) Standard arm length (arm pivot to bucket pivot)	810.0 mm

Working Range

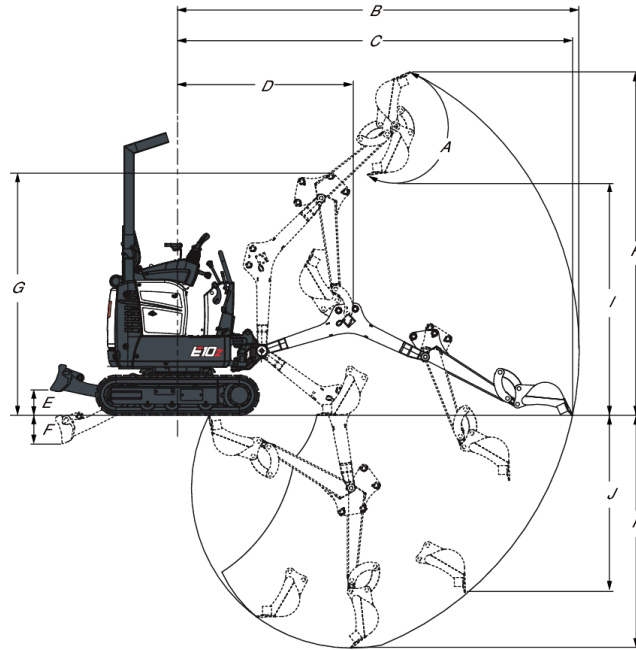

(A) Bucket pivot angle	196.0°
(B) Maximum reach of working equipment	3145.0 mm
(C) Maximum reach at ground level	3093.0 mm
(D) Maximum working equipment radius with boom at maximum height and dipperstick fully retracted	1374.0 mm
(E) Maximum blade height	196.0 mm
(F) Maximum blade depth	230.0 mm
(G) Maximum height of working equipment with dipperstick retracted	1899.0 mm
(H) Maximum bucket tooth height	2685.0 mm
(I) Maximum dump height	1818.0 mm
(J) Maximum depth of vertical wall which can be excavated	1383.0 mm
(K) Maximum digging depth	1820.0 mm

Lift Capacity

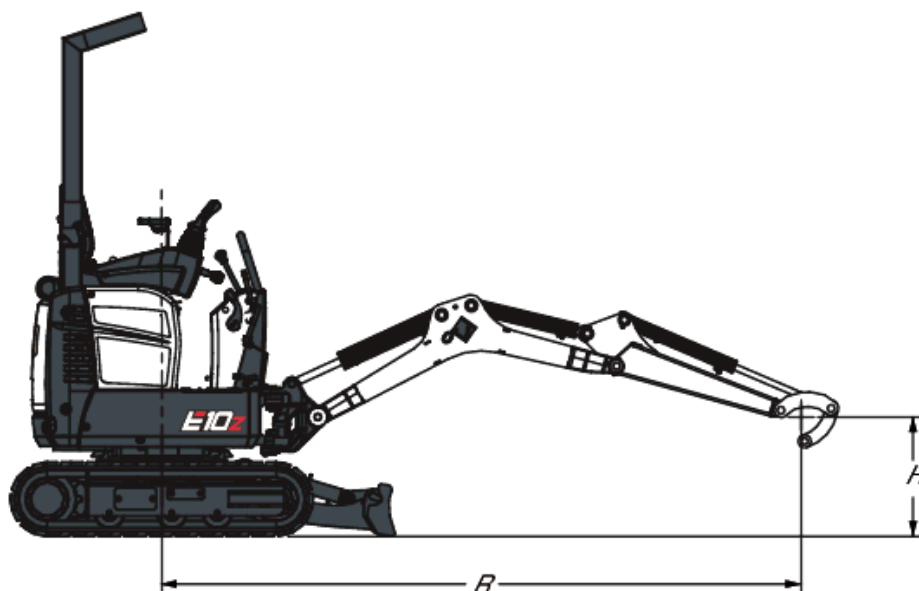

RATED LIFT CAPACITY OVER BLADE, BLADE DOWN

Lift point height [H] (mm)	Maximum radius [R] (mm)	Lift at max. radius (kg)	Lift at 2000 mm radius
2000	-	345*	329*
1000	-	309*	373*
Ground	-	264*	438*
-1000	-	229*	242*

* Rated hydraulic lift capacity with 400 mm bucket

RATED LIFT CAPACITY OVER BLADE, BLADE UP

Lift point height [H] (mm)	Maximum radius [R] (mm)	Lift at max. radius (kg)	Lift at 2000 mm radius
2000	-	208	212
1000	-	140	214
Ground	-	139	204
-1000	-	212	229

* Rated hydraulic lift capacity with 400 mm bucket

RATED LIFT CAPACITY OVER SIDE, BLADE UP, TRACKS RETRACTED

Lift point height [H] (mm)	Maximum radius [R] (mm)	Lift at max. radius (kg)	Lift at 2000 mm radius
2000	-	117	120
1000	-	71	115
Ground	-	69	100
-1000	-	106	109

* Rated hydraulic lift capacity with 400 mm bucket

Lift Capacity with cylinder covers

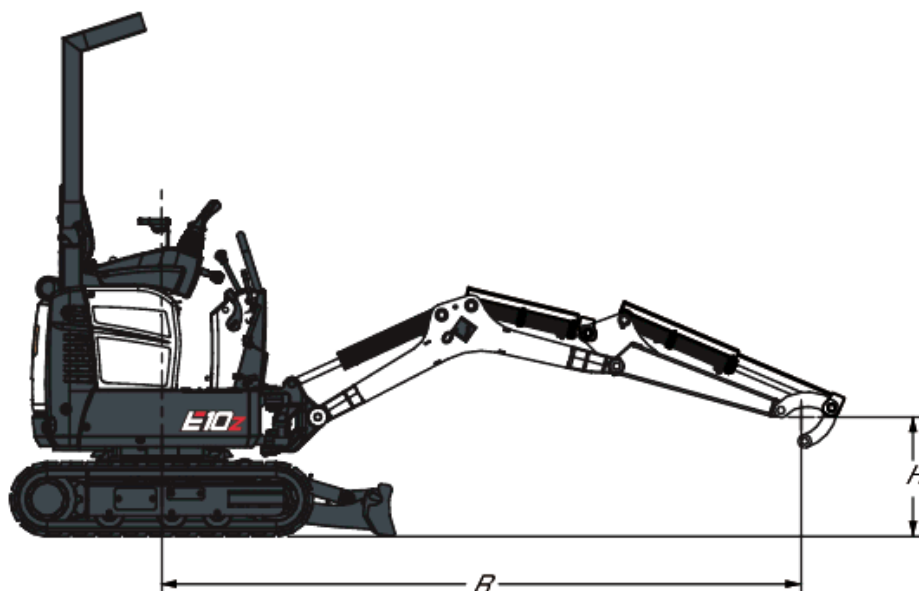

RATED LIFT CAPACITY OVER BLADE, BLADE DOWN - kg (lb)

Lift point height [H] (mm)	Maximum radius [R] (mm)	Lift at max. radius (kg)	Lift at 2000 mm radius
2000	-	332*	319*
1000	-	291*	359*
Ground	-	253*	420*
-1000	-	214*	228*

* Rated hydraulic lift capacity with 400 mm bucket

RATED LIFT CAPACITY OVER BLADE, BLADE UP - kg (lb)

Lift point height [H] (mm)	Maximum radius [R] (mm)	Lift at max. radius (kg)	Lift at 2000 mm radius
2000	-	206	211
1000	-	143	217
Ground	-	141	206
-1000	-	214*	228*

* Rated hydraulic lift capacity with 400 mm bucket

RATED LIFT CAPACITY OVER SIDE, BLADE UP, TRACKS RETRACTED - kg (lb)

Lift point height [H] (mm)	Maximum radius [R] (mm)	Lift at max. radius (kg)	Lift at 2000 mm radius
2000	-	111	115
1000	-	66	107
Ground	-	64	97
-1000	-	101	102

* Rated hydraulic lift capacity with 400 mm bucket

Performance

Digging force, dipperstick (ISO 6015)	5550 N
Digging force, bucket (ISO 6015)	8294 N
Drawbar pull	9905 N
Ground pressure with rubber tracks	29.70 kPa

Cycle Times

Boom raise time	4.2 s
Boom lower time	4.2 s
Bucket curl time	3.2 s
Bucket dump time	2.3 s
Dipperstick retract time	3.9 s
Dipperstick extend time	2.6 s
Boom swing left time	4.1 s
Boom swing right time	3.2 s
Blade raise time	1.7 s
Blade lower time	1.2 s
Slew rate	9.0 RPM
Undercarriage expand time	5.0 s
Undercarriage retract time	3.5 s

Weights

Operating weight with TOPS canopy and bucket (ISO 6016)	1176 kg
Transport mass (no attachment)	1077 kg

Engine

Make / model	Kubota / D722-E4B (Stage V)
Fuel	Diesel
Cooling	Liquid, forced circulation
Maximum power @ 2000 rpm (ISO 14396)	7.5 kW
Maximum governed speed	2000.0 RPM
Maximum torque (SAE)	40.1 Nm
Number of cylinders	3
Displacement	719 cm ³
Bore	67.0 mm
Stroke	68.0 mm
Air filter	Dual dry replaceable paper cartridge
Ignition	Compression ignited (diesel)
Starting aid	Intake air heater
Crankcase ventilation	Closed breathing
Lubrication	Forced lubrication with cartridge type filter

Electrical

Alternator	12 V — 40 A — open frame with internal regulator
Battery	12 V — 500 A cold cranking current — 90 min reserve capacity
Starter	12 V — reduction drive — 1.4 kW

Hydraulic System

Pump type	Double gear pump
Total hydraulic capacity	20.00 L/min
System relief pressure for travel circuits	184.00 bar
System relief pressure for travel circuits	192.00 bar
System relief pressure for slew circuits	84.0 bar
Auxiliary relief	190.0 bar
Main hydraulic filter bypass	1.72 bar
Control valve	Nine-spool parallel type, open centre
Hydraulic filter	Full-flow replaceable
Fluid lines	SAE standard tubelines, hoses, and fittings
Auxiliary flow	20.00 L/min

Hydraulic Cylinders

Boom cylinder	Cushion up
Boom cylinder bore	63.5 mm
Boom cylinder rod	31.8 mm
Boom cylinder stroke	312.4 mm
Dipperstick cylinder	No cushion
Dipperstick cylinder bore	50.8 mm
Dipperstick cylinder rod	31.8 mm
Dipperstick cylinder stroke	325.6 mm
Bucket cylinder	No cushion
Bucket cylinder bore	44.5 mm
Bucket cylinder rod	25.4 mm
Bucket cylinder stroke	385.1 mm
Boom swing cylinder	No cushion
Boom swing cylinder bore	57.1 mm
Boom swing cylinder rod	31.8 mm
Boom swing cylinder stroke	274.6 mm
Blade cylinder	No cushion
Blade cylinder bore	50.8 mm
Blade cylinder rod	31.8 mm
Blade cylinder stroke	96.8 mm
Undercarriage cylinder	No cushion
Undercarriage cylinder bore	44.5 mm
Undercarriage cylinder rod	25.4 mm
Undercarriage cylinder stroke	400.1 mm

Buckets

Width (mm)	Weight (kg)	Struck capacity (m ³)	Rated capacity (m ³)
200	12.7	0.0068	0.0089
300	16.1	0.0108	0.0154
400	18.9	0.0147	0.0223
800	26.2	0.0263	0.0426

Slew System

Boom swing, left	67.0°
Boom swing, right	64.0°
Slew circle	Single row shear-type ball bearings with internal gear
Slew drive	Orbit motor

Drive System

Travel motor	Each track is driven by a hydrostatic axial piston motor
Drive reduction	Two-stage planetary gear reduction 18:53:1

Traction

Track width	180.0 mm
Track adjusters	Grease type
Track type, standard	Half-pitch, rubber
Travel speed, low range	2.1 km/h
Travel speed, high range	3.1 km/h
Undercarriage	Crawler-type tractor design with reinforced box-section track roller frame and sealed track rollers
Number of track rollers per side	3
Gradeability travelling down or backing up slopes	25.0°
Gradeability travelling on side slopes	15.0°
Gradeability travelling up side slopes	15.0°

Brakes

Slew brake	Hydraulic lock on motor and pin lock
Travel brake	Hydraulic lock in motor circuit

Fluid Capacities

Fuel reservoir	16.00 L
Hydraulic reservoir	2.60 L
Final drive case (each)	0.50 L

Fluid Specifications

Engine coolant

Propylene glycol/water mix (53% - 47%) with freeze protection to -37°C

5 L can - 6904844A, 25 L container - 6904844B, 209 L drum - 6904844C, 1000 L tank - 6904844D

Engine oil

Oil must meet API Service Classification of CD, CE, CF4, CG4, or better. Recommended SAE viscosity number for anticipated temperature range.

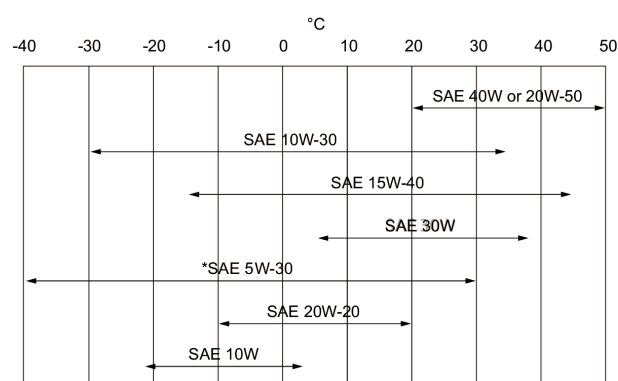

Hydraulic fluid

* Can be used only when available with appropriate diesel rating. For synthetic oil use the recommendation from the oil manufacturer.

Bobcat Superior SH, 5 L can - 6904842A, 25 L container - 6904842B, 209 L drum - 6904842C, 1000 L tank - 6904842D

Bobcat Bio Hydraulic, 5 L can - 6904843A, 25 L container - 6904843B, 209 L drum - 6904843C, 1000 L tank - 6904843D

Motor oil is not an acceptable alternative fluid.

Controls

Engine

Starting

Blade

Boom swing

Hydraulics

Hand levers on right hand side

Key-type starter switch and shutdown

Right hand lever

Right foot pedal

Two joysticks control boom, bucket, dipperstick and upper structure slew

Left-hand foot pedal

Auxiliary hydraulics

Upper structure slew lock for holding and service

Holding brake for upper structure slew

Steering

Hydraulic lock on motor

Pin lock

Direction and speed controlled by two hand levers

Instrumentation

- Air intake heater indicator
- Charging system indicator
- Engine oil pressure indicator
- Engine coolant temperature warning indicator
- Fuel gauge

- Hour meter
- Two-speed range indicator

Serviceability

Fuel filler is external and has key lock for vandal proofing

Access is available to the following through the rear tailgate or side access hood:

- Air cleaner with indicator
- Battery
- Cooling system (engine oil and hydraulic oil coolers) for cleaning
- Engine oil and fuel filters
- Engine oil level
- Fuel filler
- Starter
- Sight gauges for hydraulic level
- Sight gauge for fuel level

Central grease point for swing bearing, swing pinion, and offset cylinder

Tailgate and access cover have locks for vandal-proofing.

Easy access to all grease points.

Standard Features

- 710 mm dozer blade / 1100 mm extended
- 180 mm rubber track
- Auxiliary hydraulics on boom with quick couplers
- Control console locks
- Horn
- Electronically activated track expansion
- Hydraulically expandible undercarriage from 710 to 1100 mm
- Retractable seat belt
- Seat
- Two-speed travel
- TOPS canopy ¹
- Vandalism protection
- Water separator
- Work light
- Warranty: 24 months, 2000 hours (whichever occurs first)

Options

- Auxiliary double action
- Auxiliary on arm
- Beacon
- Demolition package (arm, bucket cylinder covers & HD travel hoses guard)
- Grease Gun w/ holder
- Hydraulic oil cooler
- Keyless ignition
- LED light
- Object handling device (lifteye)
- Spark arrester muffler kit
- Travel motion alarm

1. Tip Over Protective Structure (TOPS) – Meets requirements of ISO 12117

Attachments

- Breaker Accessories
- Breakers
- Clayspade Buckets, Pin-on
- Digging Buckets, Pin-on
- Grading Buckets, Pin-on
- Laser Equipment

Environmental

Noise level LpA(EU Directive 2006/42/EC)	80 dB(A)
Noise level LWA(EU Directive 2000/14/EC)	93 dB(A)

Safety

Retractable seat belt, standard	Should always be worn when operating the excavator A two-post canopy or optional closed cab. Meets ISO 12117 for Tip Over Protective Structure (TOPS).
Operator cab, standard	
Grab handles, standard	Should always be used when entering/exiting excavator. Slip resistant tread on canopy threshold to be used when entering/exiting excavator.
Safety tread, standard	
Front working lights, standard	Use for indoor and low light operation. Operator console locks out work group and travel functions when in the upright position.
Control lockout, standard	
Upper carriage slew lock, standard	A lock pin is provided to lock the upper structure to the undercarriage for transport.
Pedal lock, standard	Prevents activation of the boom swing function.
Travel motion alarm, optional	For use when required
Special applications kit, optional	Weather-resistant operator handbook attached to the underneath of the seat, providing operational instructions and warnings decals with pictorials and international symbols.
Operator's handbook, standard	